

## Preface

PS2 Heavy automobile computer diagnostic tool is a major product of Xtooltech Co. Ltd. Our technicians in programming and R&D section play a technical leading role in this business. Most engineers have rich experiences for designing platform and software. Therefore, our custom will feel the outstanding and powerful performance of the product.

As for the design of PS2, our technicians perfectly mix appearances with practicality. With jumbo size, true-color, full touching screen and simple body, customers will operate PS2 more intuitively and easily. The capability of the built-in highly processing chip could reach 400MHZ. Its ability is superior to the common used ARM7 chip. Such excellent performance of the chip and the superior diagnostic module will guarantee the accuracy and real-time function. The demonstration for data stream of PS2 shows its accuracy and rapidity which will enhance the convenience of our guests.

In the compatible aspect of data agreement, PS2 comprehensively supports all protocols and all modes for the OBD II. The built-in CAN BUS chip supports all CAN BUS agreements. The forward-looking design of PS2 meets the need not only for the present but also for the future automobile main-line examination. The drivers of diagnostic module can be updated through the internet. The formidable compatibility reduces the equipped adapter. PS2 is easy to handle and users will experience the unique design from our R&D team.

We also provides wireless communication version of PS2. The servicemen can sits in the office to carry on the functional test. The VAG connector could meet the various requests from customers. All test procedures places on a high-capacity SD card which facilitates the updating procedure. The mult-language edition will satisfy the demands from our customer around the world.

As a result of massive field test, PS2 becomes a matured and integrated product. Excellence is our motto. We make every effort to develop and to innovate our product which enables PS2 to become an reliable automobile diagnostic equipment. The speedy test, the accuracy and the user-friendly design of SP2 help us to enjoy the support of all customers!

PS2 is a high-tech and professional automobile diagnostic tool. Please follow the instruction to use the product. If you have any problems or questions related to the operation, please contact post-sale Technical service department for further instruction.

## Statement

- (1) This manual is designed for the PS2 product, any company or individual are not permit to replicate and backup it in any form if they don't have the authority license from XTOOLTECH CO., LTD (include electronic, mechanical, photocopying, recording or others).
- (2) PS2 heavy duty is just offered for the professional and technical personnel of vehicle maintenance
- (3) This manual only provides methods of operating PS2 products, our company does not undertake any responsibility if it result in any consequences by operating other equipments.
- (4) XTOOLTECH does not undertake any responsibility if the equipment is damaged or let users cost or loss any expenditure because of the user's personal or third-party's accident; or abuse or misuse of the equipment; or unauthorized alteration and repair; or wrong operating not guide by manual, etc.
- (5) The manual is based on the existing configuration and functions, and it will also be subject to change if the tool is added new configuration and new features, but please pay attention that we wont notice it specially.
- (6) XTOOLTECH Company has conducted a registration of trademarks, the logo is 
- (7) XTOOLTECH Company claim that it still owns the ownership of trademarks, service marks, domain names, logos and company names among the nationals where those have not yet be registered . The other products and other company names mentioned by the manual still belong to the original registered companies. nobody can use the name of XTOOLTECH or the trademarks, service marks, domain names, logos and company names if without the formal agreement written by the consent of the XTOOLTECH owner,
- (8) You can access the web site: <http://www.xtooltech.net> to learn more about the related information of PS2 equipment.
- (9) XTOOLTECH company owns the final interpretation of the manual contents.

**Directory Lists**

**Chapter one** acquaintance of Product .....4

A. diagram of PS2 mainframe appearance .....4

    1.Front-View Figure .....4

    2.Back- view Figure ..... 4

B. PS2 mainframe Interface Schematic ..... 4

    1 The upward-side connection of the mainframe ..... 4

    2. The lower-side connection of the mainframe.....5

C. Shape Schematic of VCI diagnostic box..... 5

D. PS2 technical parameters ..... 6

E. Package parameters.....6

**Chapter two** operating the product .....7

A. Calibration of display.....7

B. Main screen and function-keys notes.....8

    1, PS2 main screen.....8

    2, PS2 sub-menu.....8

    3. Function-keys notes for main screen.....8

    4, Function-keys notes for sub-menu.....9

C. Setting mainframe.....9

    1. Checking the information of mainframe.....10

    2, setting mainframe..... 10

    3, notes of setting function menu.....10

D, install printing paper..... 15

    1, notice .....15

    2, the installation of printing paper ..... 15

E. connect and diagnose with vehicles by PS2.....16

    1, testing of connecting vehicle.....16

    2, notes of connecting and diagnosis vehicle.....16

F, the method and function of using PS2.....17

    1, selecting menu..... 17

    2, operating the testing function.....20

    3. Read vehicle information.....31

**Chapter three** Places of diagnostic seat in different vehicle models.....33

**Chapter Fourth** The definition of diagnostic seat and the communicational protocols.....34

A the definition of diagnostic seat and the diagram.....34

    1, the standard OBD II Diagnosis seat.....34

    2, Round 16PIN diagnostic seat.....34

    3, Round 37PIN diagnostic seat.....34

    4, Round 38PIN diagnostic seat t.....35

    5, Round 9PIN diagnosis seat .....35

B Using the multi-jumper box.....36

    1, the multi-jumper box.....36

    2 note of the side hole on multi-jumper box.....36

    3 using method of multi-jumper box.....36

**Chapter one** acquaintance of Product

**A, diagram of PS2 mainframe appearance**

1. Front-View Figure



2, Back- view Figure



**B. PS2 mainframe Interface Schematic**

1. The upward-side connection of the mainframe:

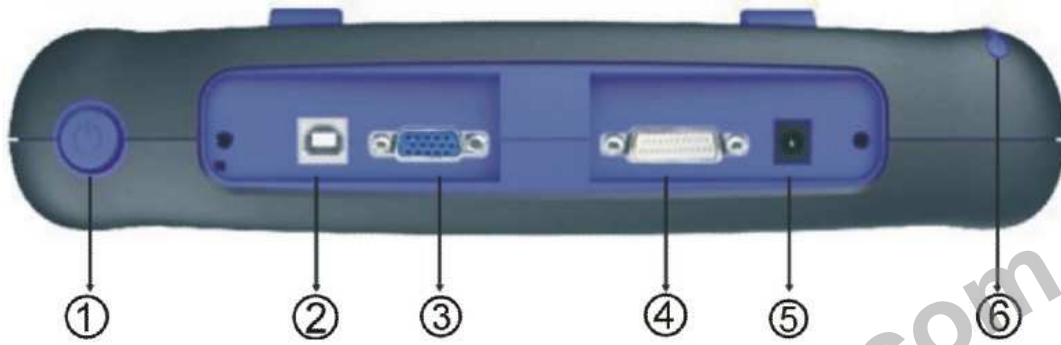

**Schematic diagram notes:**

- ① Power switch: Uses for starting and closing of main engine
- ② USB connection: Uses this connection to carry on the data synchronization with PC.
- ③ VGA connection: Uses this connection to link the external monitor (800×600 pixels)
- ④ Main test connection: Uses the testing line to carry on the vehicles diagnosis.
- ⑤ power connection: Uses for the exterior power supply
- ⑥ touching pen: Uses in clicking on the touching-screen.

**2. The lower-side connection of the mainframe**

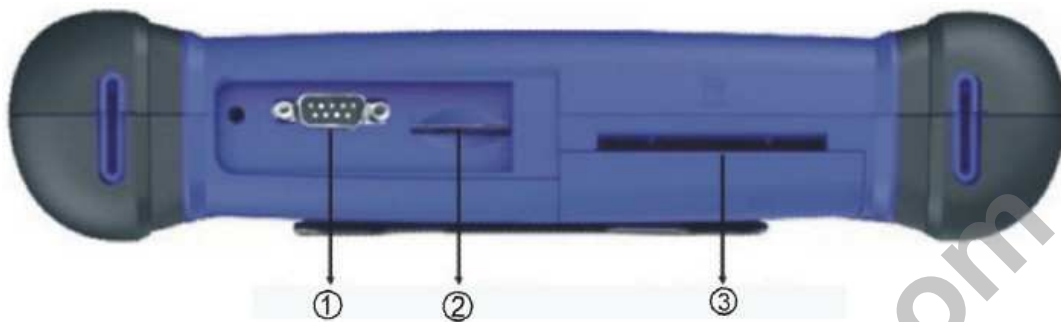

**Schematic diagram notes:**

- ① serial port: Uses in the main body debugging.
- ② SD card slot: uses for SD card
- ③ paper outlet: use for mini printer

**C. Schematic diagram of VCI diagnostic box:**

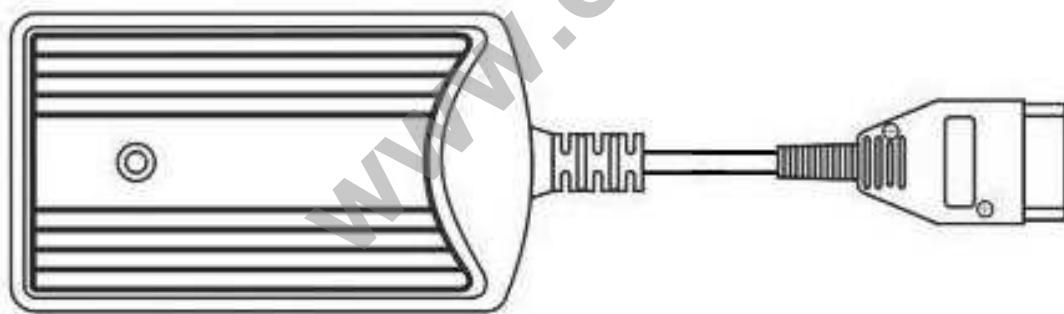

**Function:**

The box is bridging the PS2 mainframe and the automobile diagnostic base. It is called lower position machine. This diagnostic box has two connections, the DB15 connection and the OBD II connection. The main testing line connects the PS2 mainframe with the DB15 adapter. The OBDII connection could link with the testing adapter (PS2 with OBDII diagnostic base could directly link with automobile connection base)

Because the blue-teeth communication module is installed in the VCI diagnosis box, the PS2 mainframe could proceed the diagnosis without the main testing line. The “on-line diagnosis” should be changed to the “wireless diagnosis” mode on the menu. serial port: Uses in the main body debugging.

**D . PS2 technical parameters:**

- ① operating system: WINCE 5.0 operating platforms
- ② CPU: SAMSUNG 32 bits processors, basic frequency is 400MHZ random memory: SDRAM 64M
- ③ programming memory: FLASH 64M ,supports SD card slot-in and slot-out
- ④ mainframe battery: rechargeable battery 3500m/Ah
- ⑤ mainframe power supply: DC12V/24V
- ⑥ mainframe power: 25W
- ⑦ printer: Mini high-speed thermal sensitive printer
- ⑧ screen: 8 inches real-color touch-screens, 800×600 with LED back-light
- ⑨ relative humidity: <90%, temperature: -20-50℃
- ⑩ wireless communication: blue-teeth

**E. Package parameters:**

- ① machine composition: mainframe with SD card, touching pen, testing adapters, group of lines, SD card adaptor, operation manual and outside suitcase
- ② overall size: 305.2×215.2×85mm
- ③ weight: 10KG

## Chapter two operation of the product

### A. PS2 display calibration

1, When the host boot, tap anywhere to access the screen calibration program interface, as shown below. ▼



2, Please click on the center of the cross calibration of the main screen cursor after entering into the screen calibration program interface, (cross cursor will turn in the middle of the screen, upper left, lower left, lower right, upper right corner of the five points. Each click will move the cross cursor to the next position. more accurate you click, better the function of calibration will be. the screen will mention you to click on anywhere to store the current calibration value after five directions are followed by click,, then the main interface will turn into the boot.) As shown below. ▼

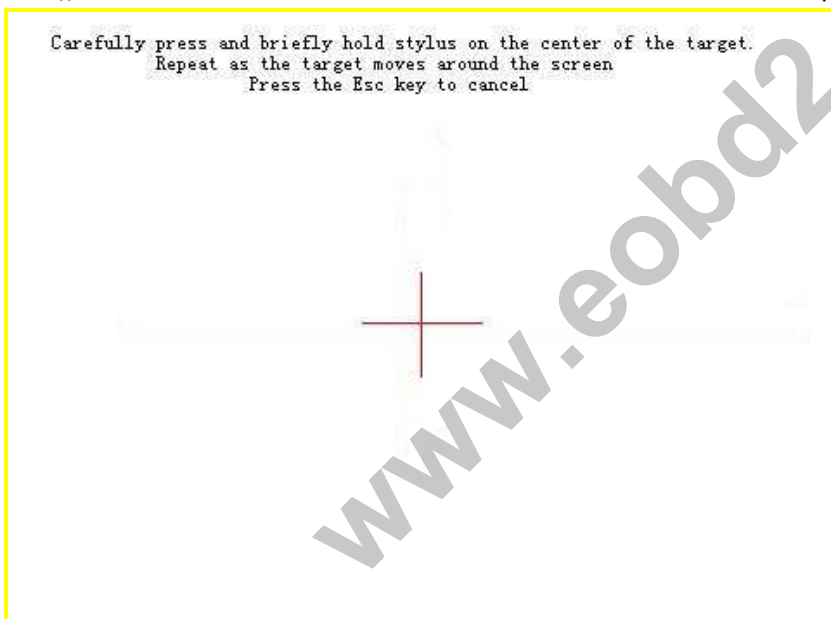

Tip: Typically, the screen is no need to be calibrated in each using time, but it should be done in the sense of the using of touch- screen is inaccurate or its difficult to click



the selected menu. Touch-screen calibration also can be set on the setting function of main manu as it is powered

**B. main screen and function-keys notes**

1, PS2 main interface

Main interface is shown as below after PS2 is turned on ▼



2, PS2 sub-menu.

You can click 【PgUp】 or 【PgDn】 key to select the page as it enter into the "Diesel"





sub-menu, the interface as shown below ▼











3, The main interface Function Keys:

Function keys	Function notes
---------------	----------------



	mainframe information button, click on the button, it could display its information (including software and hardware version, release date and product serial number, etc.)
	Settings button, click on this button will display the main setup menu.
	Help button, click on this button will display help information, technology information.
	Wireless Bluetooth signals prompt.
	Host battery tips.

4, the sub-menu Function Keys:

Function keys	Function
	Home button, click the button to return to the main interface.
	Capture key, click on this button, display pictures could be captured and be stored in the "Snapshot" folder of SD card.
	Help button, click on this button, can check the relevant using assistance and technical information.
	Return key, click on this button, can return to the previous screen from the current screen.
	Flip key, click on the button will turn the current interface is based on the previous interface.
	Scroll down key, click the button next will be based on the current turn to the next screen interface.
	OK button, the selected menu or function to determine action.
	Print button, click on the Print Screen key host to the currently displayed information.

C. setting mainframe interface

1. checking the information of interface

Click the button **About** at the bottom of the main interface to display the host software and hardware version, release date and product serial number

Information, as shown below. ▼

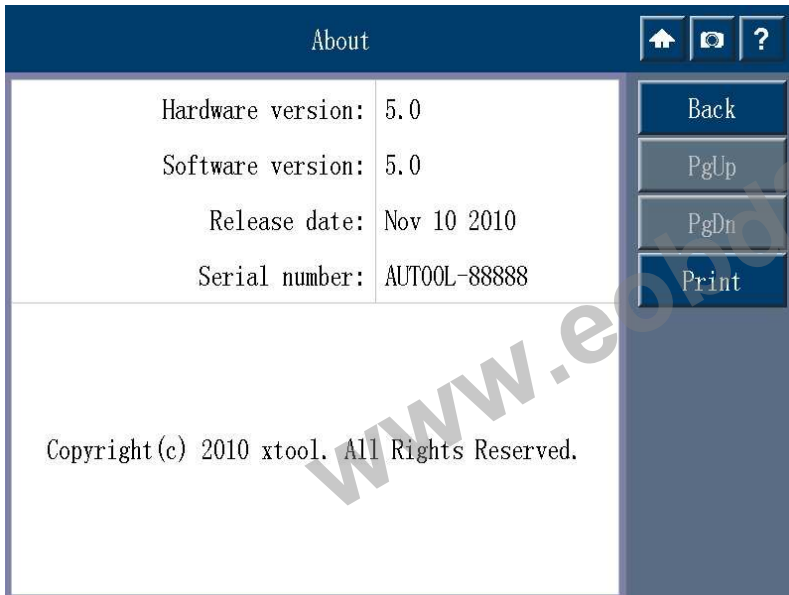









2, setting interface

Click the button **Options** below, then shows the host settings menu, can choose setting as shown below. ▼



3, notes of setting function menu

menu	Notes of menu
------	---------------

 Language	Language settings menu, to enter the menu can be a more active language
 Touch	Screen calibrated menu, to enter the menu to calibrate the screen.
 Brightness	Brightness adjustment of the menu, to enter the menu is a brightness adjustment on
 Buzzer	Buzzer set menu. to enter the menu can be a buzzer at the opening or closing set
 EN/Metric	And the toggle menu, to enter the menu to the public, can switch the EN/METRIC.
 Display	Display settings menu, to enter the menu are subject to choose and the control buttons place setting.
 User Info	User to enter the menu, and can enter a user information.
 Serial port	USB connection settings menu, to enter the menu can be set up pc host and connectivity communications and data synchronization.
 PC Connect	Online diagnosis set menu. to enter the menu can be set on a wired or wireless host medical diagnosis settings.



A. Language settings  
click the "language" In the interface, the menu icon into the language settings menu interface, choose the language as shown. ←

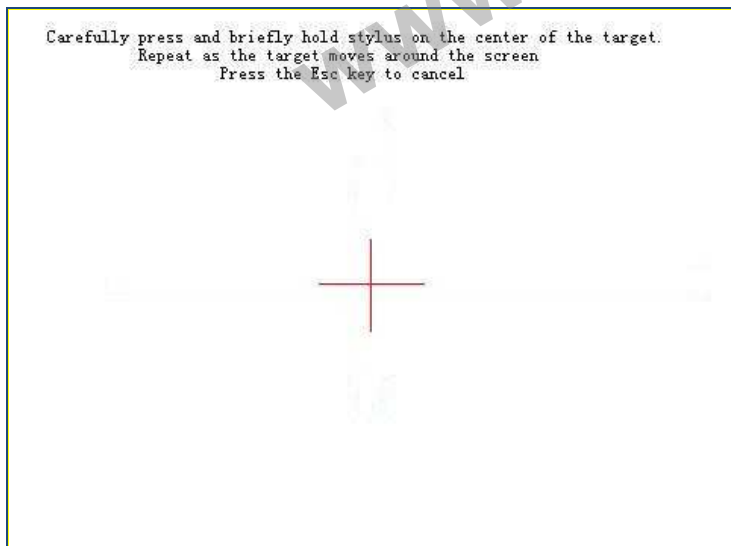

B. click the "display calibrated" on setting screen, the calibration method is introduced before, screenshot is shown as ←

←



C. adjust Screen brightness  
Click the "brightness" on the setting interface, click the brightness strip from left to right to choose he brightness you need , screenshot is shown as ←



D. Buzzer setting  
, click the "buzzer" In the interface to set, a buzzer opening or closin。  
Screenshot is as shown ←

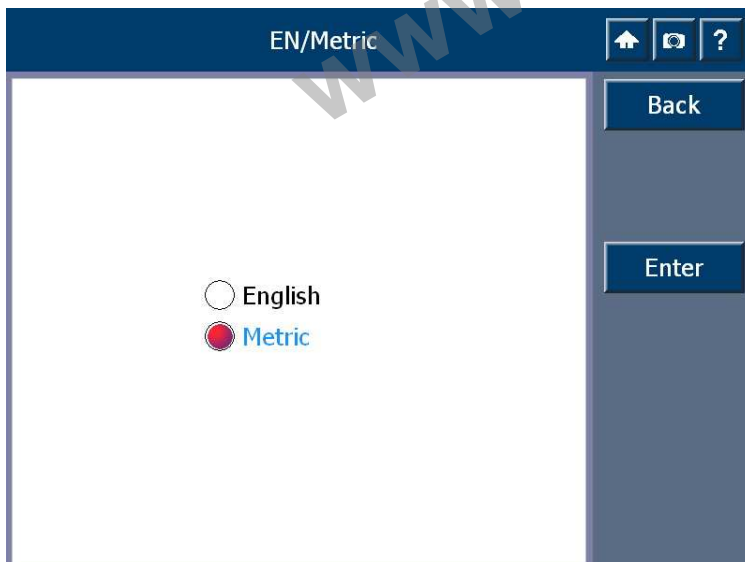

E , EN/METRIC switch  
click the " EN/METRIC" In the interface menu to choose your need  
screenshot is as shown ←

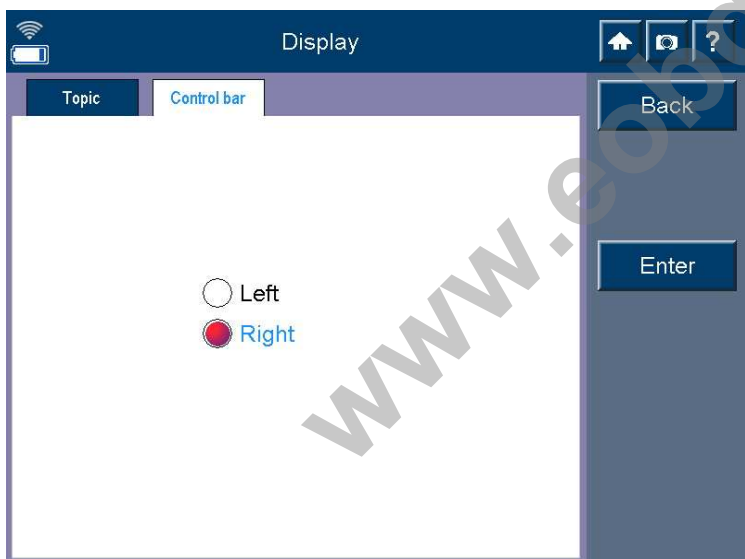

F. Display settings  
click "Display" menu In the interface to choose the theme selected, or to set control button on the left or right as you used to.  
Screenshot is as shown ←

**User Info**

Name: \_\_\_\_\_

FirstName: \_\_\_\_\_

Tel: \_\_\_\_\_

Fax: \_\_\_\_\_

Mobile: \_\_\_\_\_

Company: \_\_\_\_\_

Title: \_\_\_\_\_

Address: \_\_\_\_\_

zipcode: \_\_\_\_\_

Back

Enter

Ins	Del	Home	End		←	↑	↓	→						
~	!	@	#	\$	%	^	&	*	{	}	0	-	=	<Bspc
Tab->	Q	W	E	R	T	Y	U	I	O	P	{	}		\
Caps	A	S	D	F	G	H	J	K	L	:	"	'	Enter	
Shift	Z	X	C	V	B	N	M	<	>	?	/	.	Shift	

G. User information

Click "user info" in the interface, you can enter your user info. the input keyboard will automatically pop up as you enter the menu, the information will be printed out when it's print.

**USB Connect**

Back

Enter

Disable

Enable

H. USB connection settings  
click "USB Connect" In the interface, host can be set prohibited or permitted to connect with the pc communication

**PC Connect**

Back

Enter

With wire

Wireless

I. Online diagnosis

Click "PC Connect" in the interface, host can be set diagnostic testing by wired or wireless

## D. To install Printing paper

### 1, Notes

- ① The standard of printing paper is  $\Phi$  30mm X 57mm and inner hole is  $\Phi$  10mm for thermal paper
- ② Thermal paper must be put far away from high-temperature place, or it could lead to abnormal showing, fuzzy-printing or black-stone on the printer paper.
- ③ It cant be print out normally if the paper Installed negatively

### 2、 installation for printing papaer

- ① Take the printer cover off from the mainframe-back, hold down the printer cover to push back toward the direction of the arrow to open, as shown below ▼
- ② take out the printer-roller, install the printing paper positively, then plug the roller into the inner hole, as shown below



- ③ Stretch out some typing paper, and ensure that the edge of typing paper is on a parallel with printing box, then push back the cover as shown below ▼

- ④ it can print after the cover is installed , if paper cant print smoothly, please check if paper installed unfit; if it cant print out words, please check if paper installed negatively ▼





## E. connect PS2 to diagnosis vehicle

### 1、connecting test with PS2

- ① Please check if the SD card is put into the mainframe correctly
- ② Connect mainframe with VCI diagnostic box by main testing line
- ③ find out the corresponding testing connector in the PS2 suitcase according to the type of vehicle diagnostic block, then connect VCI box with vehicle diagnostic block by testing connector
- ④ you can use the universal jumper box to test if in case there is no suitable connector in suitcase, but please pay special attention:
  - a. please test the diagnostic block by multimeter before connecting, so as to confirm its anode, Negative electrode, K communication line or CAN BUS communication line
  - b. please pay more attention to avoid shaking hand lead to short circuit and destroy the electronic components as the distance of diagnostic block's terminals is very small.
  - c. Wrong connection will destroy ECU or the electronic components in mainframe, for example, wrong connection with anode and negative electrode, or treat anode as K line, which would destroy diagnostic equipment. While it will lead to no way to enter into the system if H line is wrongly instead connect with L line of CAN BUS communication .
  - d. more illustration about diagnostic block components and jumper line, please check page 38.
- ⑤ Its ready to diagnose vehicle as the electricity- light switch turned on and the power button pressed down

The connecting diagram is shown as follows:

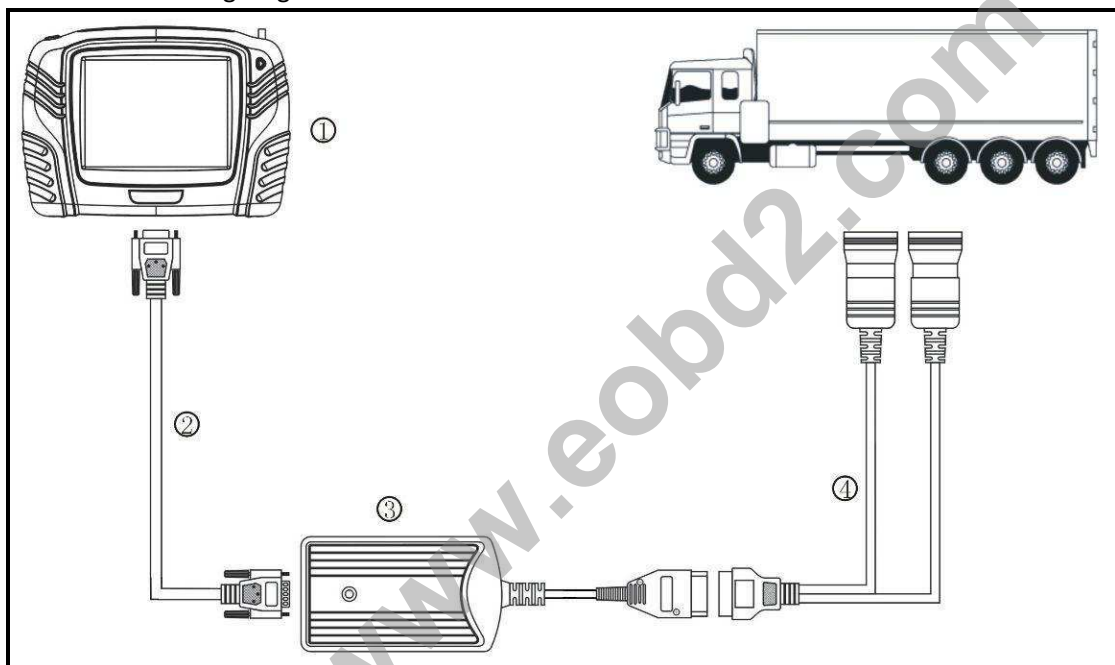

① : PS2 主机 ②: 主测试线 ③: VCI 诊断盒 ④: 测试接头

### 2、 Notes of connecting diagnosis

- ① The power should reach to the normal working voltage, 12 V or 24 V
- ② the hand should pinch the front of harness to Pull or insert the testing wire, cant pull the middle part forcibly. Please check if it is flat after inserting, cant slant to insert so as to invoice destroying the terminals.
- ③ The user should operate by the illustration as testing special function. For example, the factors of Off-cylinder test for some vehicles are as follows: the water temperature of engine is 80°C -105°C, should close light, air condition and loosen pedal fast etc.
- ④ as the diesel machine and the electronic control system are usually complex, so if it cant test or testing data is wrong, please check out the correct ECU model, then choose it to correspond with the menu
- ⑤ Maybe it should update the software If you cant find out the vehicle model or diesel electronic control system in the menu. Or contact with technical service department.
- ⑥ No using the harness not produced by xtooltech in order to avoid unnecessary loss.
- ⑦ No plugging out SD card in terms of diagnostic testing in order to avoid losing data.
- ⑧ No power off directly in terms of communication with PS2 and vehicle, please cancel the task first, then back to main interface, and then power it off.
- ⑨ Please using it gently and no shaking and striking. Please touching screen gently so that it can be used as long as possible.
- ⑩ please power it off if long time no use it.

## F. Using method and functions

### 1、 Menu choosing

- (1) As connecting PS2 with vehicle successfully, Press down power key, enter into the main menu , shown as follows ▼



(2) choose menu according to your need: ▼



(3) example for HINO, choose “engine”, then see “HINO” logo, if not, please click 【PgUp】 or 【PgDn】 to find it, shown as follows:

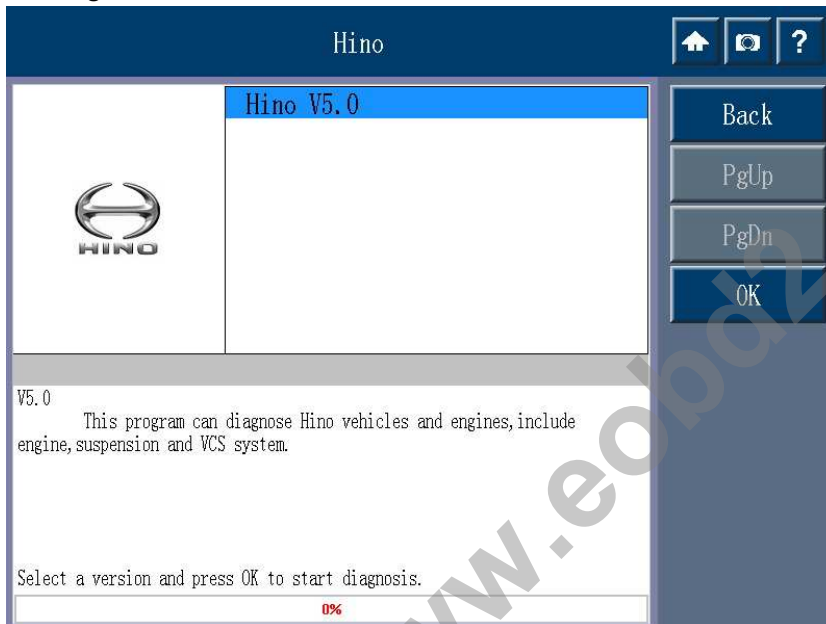

(4) If the screen display multiple versions, usually choose a higher edition, click on 【OK】 , then enter into 【HINO】 menu, and then choose what you want, the menu is shown as follows:



(5) Take diagnose “Engine” as example, turn the ignition key to “ON” position, after select “Engine” menu, PS2 diagnostic box will communicate with ECU of the car, meanwhile the screen will display a communication status as the picture shows below. ▼

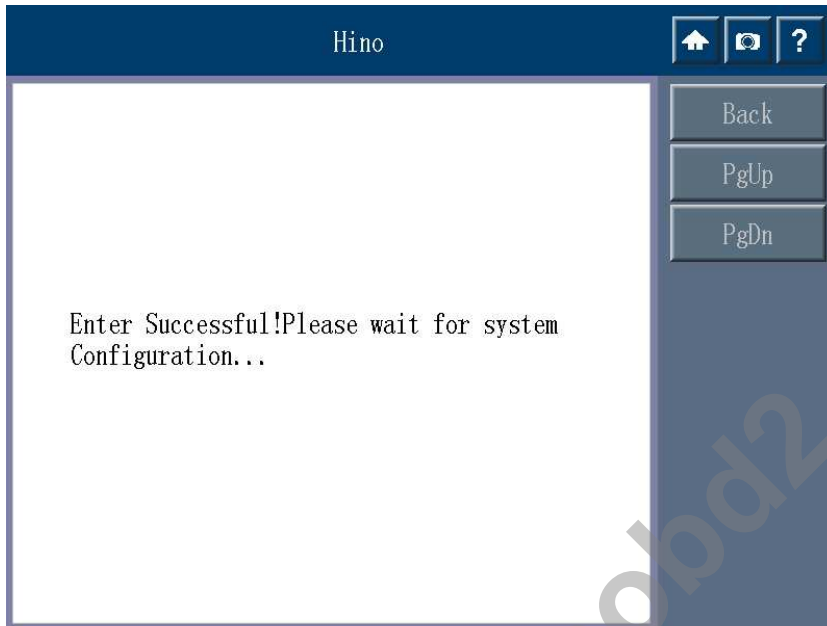

(6) If the communication between PS2 and ECU of the car is failed, the screen will show “test failed” as the picture shows below. ▼



**Note: If the screen shows the failure, it would be caused by the following reasons:**

- ① The ignition key is not turned to the "ON" position, please turn the key to "ON" position or power on the engine.
- ② The connecting wires or the diagnostic seats are not connecting successfully, please recheck if the connection is good.
- ③ Testing menu was wrongly selected, make sure the electronic control system is good and then select the correct menu to test.
- ④ The testing software is not yet updated, please update the software in time.

## 2、Operation the Testing Functions

(1) If the communication is regularly working, the screen will show relating information or model of the system, as the picture shows below. ▼



(2). Press **【OK】** key and the relating testing function menu of the system will show up, the different car model or different system will result in different testing menu, as the picture shows below.▼

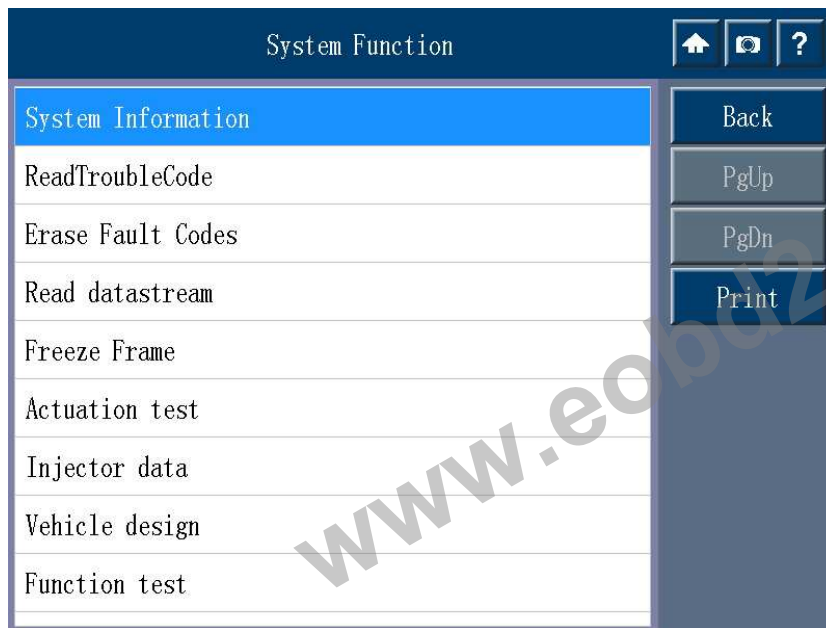

(3) Function of reading ECU information

This function is to read the ECU information, it's shown as "system identification" or "system information" in some drive-by-wire(电控), however, they have the same meaning which is to read the information such as software version, hardware version, etc of ECU. The picture shows as below ▼



(4) Function of reading fault code

Selecting "read fault code" function to read the fault code saved in the ECU electronic control

system, if there are no fault code in ECU, it will show "no fault code present" or "system is normal", as the picture shows below. ▼



**Note:** when diagnosis the car, if it shows "system is normal" or "no fault code present", it means that there is no fault code saving in ECU or there are some other faults which can not be detected by ECU, mostly those undetected faults are machine system faults or executive circuit faults, also it is possible that sensor causes some signal windage in a certain scale. We can judge the fault from data stream function.

(5) If there are fault code existing in ECU, the screen will show all the fault codes and its definition when reading the fault codes, the picture is as follow. ▼

The screenshot shows the Hino diagnostic software interface displaying a list of fault codes. The brand name 'Hino' is at the top. Navigation icons (home, camera, question mark) are present. The main display area contains a table of fault codes. To the right of the table, there are four buttons: 'Back', 'PgUp', 'PgDn', and 'Print'. A large watermark 'www.eobd2.com' is visible across the screen.

Code	Description	Status
P2122	Accelerator sensor circuit 1 low voltage	Current
P2127	Accelerator sensor circuit 2 low voltage	Current
P2120	Accelerator sensor 1 and 2 malfunction	Current
P0193	Common rail pressure sensor circuit high voltage	Current
P0118	Coolant temperature sensor circuit high voltage	Current
P0188	Fuel temperature sensor circuit high voltage	Current
P0188	Fuel temperature sensor circuit high voltage	History
P0193	Common rail pressure sensor circuit high voltage	History
P0118	Coolant temperature sensor circuit high voltage	History

**Note:** Normally, the fault codes which are detected at the first time is not regarded as the



correct evidence to eradicate the faults. Because when driving the car or one of the systems is running, ECU will diagnose the entire system continuously, and the faults would be recorded caused by the driving environments and the wire artificially plug-in or draw. Maybe problems caused by this has nothing to do with the car faults which are going to be eradicated so that repair the car fully in accordance with the fault codes will easily lead to incorrect judgment.

The correct way is to do some simple record of the fault codes after the first time reading, then erase the fault codes and read the fault code again. If there are still some fault codes can not be erased, it means that this fault code indicates some problem that should be fixed. If all fault codes can be erased but the problems are still existing there, then we can start off the car and connect to the equipment to read the fault codes after driving. Provided that a certain fault code keep showing up then this code is really existing, then this fault part should be repaired accordingly.

(6) Function of reading freeze frame

Go back and select “freeze frame” to read the freeze frame data. For instance, when reading the freeze frame data of fault codes of “P0188”, choose fault codes of “P0188” then select **【freeze frame】** then the freeze frame date will show up, as the picture shows below.▼





Note: normally only the ECU with high standard configuration has freeze frame function, freeze frame data is that when recording a certain fault code, it will also save all data relating to this fault code in ECU module including input and output data. It would help the serviceman to understand under what situation does the fault code happen, it's helpful to analyze the fault codes.

(7) Function of erase fault code

Go back and select "erase fault code" to erase the current and history memory saved in ECU, this function will erase all current and history fault codes, please make sure if you have recorded the fault codes before erasing. As the picture shows below ▼

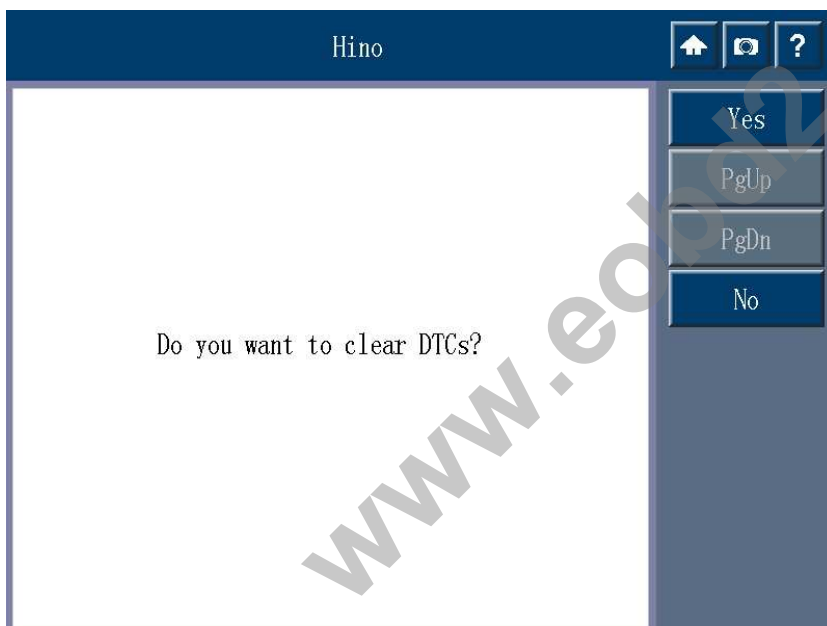

(8) After press **【Yes】** to erase the fault codes, if the communication is regular then it will Show

“Erase fault codes successfully” or “Fault codes are removed”, normally after erase the fault codes it needs to read fault codes again to make sure if the fault codes are erased. As the picture shows below. ▼

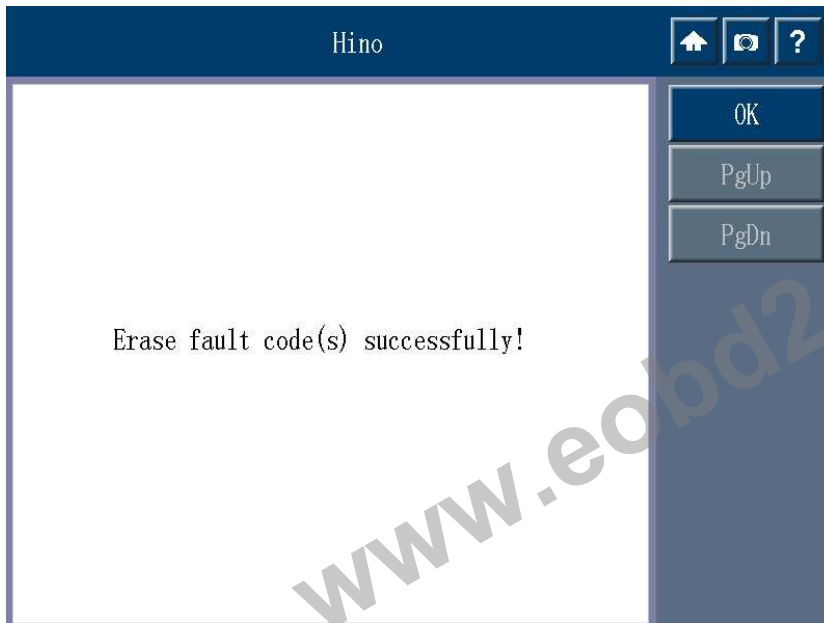

(9) Function of reading datastream

Go back to the testing function menu, select **【read data stream】** to dynamic and static Data stream of this system.

Note: Optional read can be selected when reading the data stream, you can select the items in accordance with your need. When reading the data stream, normally the engine will keep running, some data items can be read when the engine is static, as the picture shows below. ▼

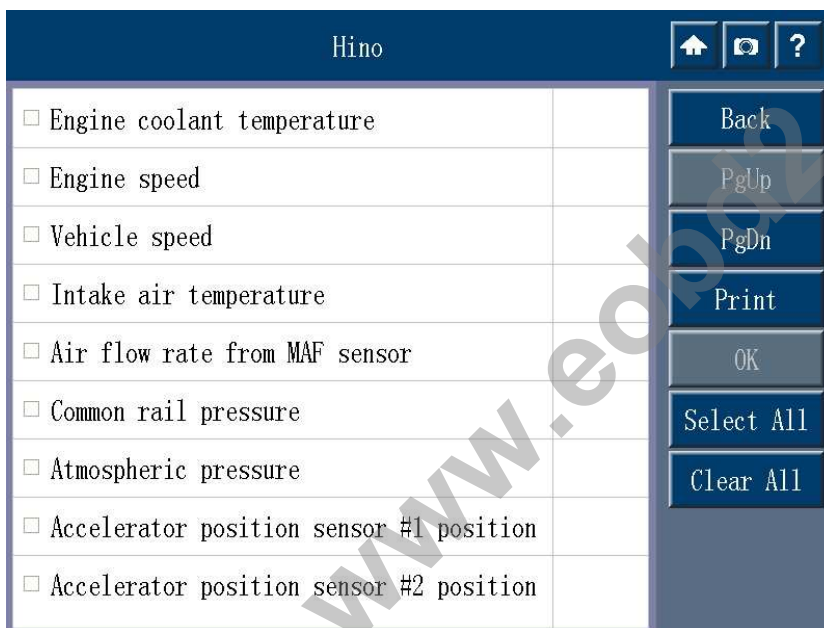

(10) After the data items are selected, press **【OK】** to show the real-time data, take reading the selected data stream items as example, as the picture shows below. ▼

Hino

<input checked="" type="checkbox"/> Engine coolant temperature	1	Back
<input type="checkbox"/> Engine speed		PgUp
<input type="checkbox"/> Vehicle speed		PgDn
<input checked="" type="checkbox"/> Intake air temperature	2	Print
<input checked="" type="checkbox"/> Air flow rate from MAF sensor	3	OK
<input type="checkbox"/> Common rail pressure		Select All
<input type="checkbox"/> Atmospheric pressure		Clear All
<input type="checkbox"/> Accelerator position sensor #1 position		
<input type="checkbox"/> Accelerator position sensor #2 position		

Hino

Engine coolant temperature	80	°C	Back
Intake air temperature	25	°C	PgUp
Air flow rate from MAF sensor	0.00	g/s	PgDn
			Print
			Pause

Note:: data stream function is an important function for the serviceman to make a further judgment, it requires the serviceman to have a good understanding on the sensor data, Control signal and control method of every system of the car, it's also the basic knowledge for the serviceman to use data stream function.

(1) Actuation test function

Go back to the testing function menu, after select "actuation test" it would show the available actuation tests of the system. ▼



Note: "actuation test" is to do function test for some certain parts of the system, when executing this function, diagnostic tool will analog ECU signal to execute movement testing to executive sensor so as to judge whether the executive sensor or wire are working good or not.

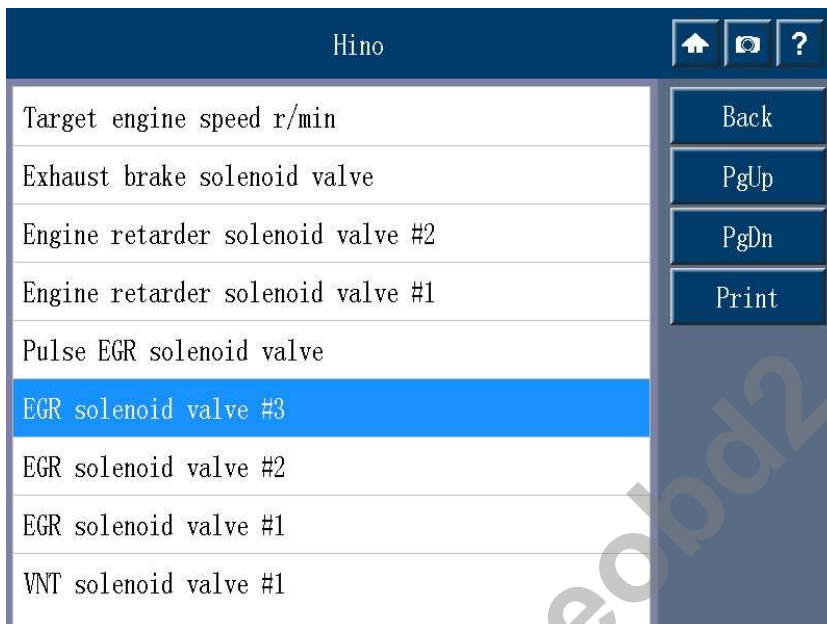

(12). Taking "EGR solenoid valve" test as example, press "EGR solenoid valve" menu to test EGR solenoid valve and the wire, then observing that whether the EGR solenoid valve has the movements in correspondence with the diagnostic tool command or not so as to make sure whether this sensor and wire are working normally or not. As the picture shows below. ▼

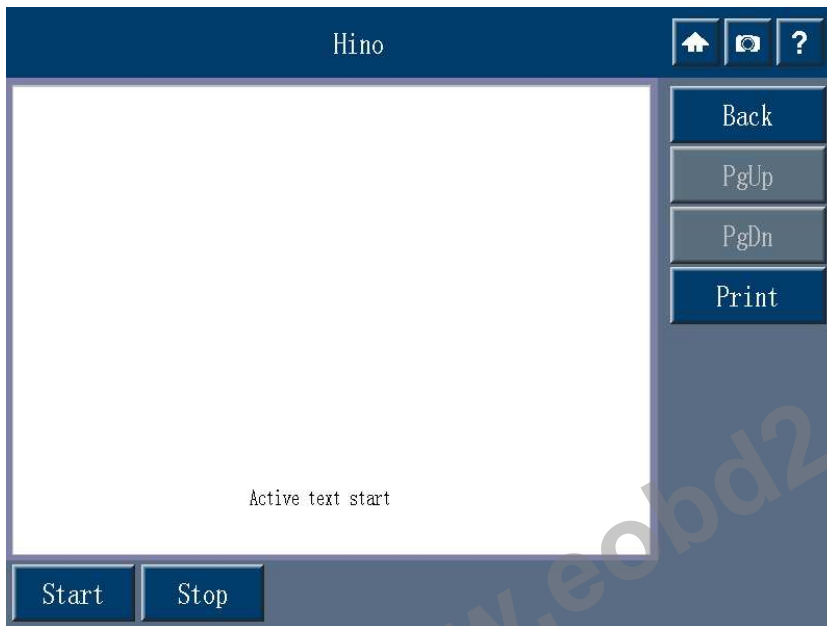

(13) Function Test

Return to the test function menu interface you can choose to enter "function test" menu, as shown below. ▼



**Tip:** Function test is the advanced features of diagnostic equipment for electronic control diesel, maintenance operations officer in the execution of the operation must be carefully read tips and precautions, and strictly follow the prompts. Some features test is under the condition of engine static item is executed, while some function testing items is in the engine operating state implementation. Some functional test must be met to perform corresponding conditions, For example: the water temperature in the normal working temperature of 80 °C-105 °C, release the accelerator pedal, air conditioning, headlights and other load off and so on.

(14) Take "VNT Check" for example, after selecting "VNT Check" menu, it will display the necessary conditions or operation tips prompted for functional testing, it can be start test after confirm, as shown below. ▼

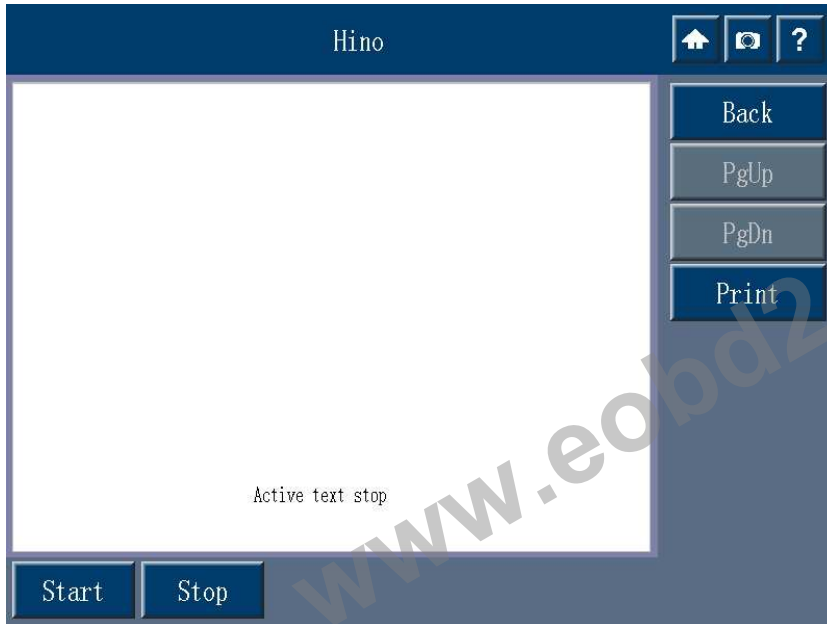

(15) Read and write of Nozzle code (QR code)

In the test function menu screen select "injector data" function to display the read, write, Nozzle Data menu, as shown below. ▼



(16) After selecting "read QR" menu immediately you can read the data out of the engine nozzle, as shown below. ▼



Hino		↑	📷	?
#1 INJ	72808080808080808080808080800072	Back		
#2 INJ	72808080808080808080808080800072	PgUp		
#3 INJ	72808080808080808080808080800072	PgDn		
#4 INJ	72808080808080808080808080800072	Print		
#5 INJ	72808080808080808080808080800072			
#6 INJ	72808080808080808080808080800072			

(17) If you want to write a new nozzle of a cylinder encoding, just in "injector data" function, select "wright QR" menu, you can write code injector, take writing the sixth cylinder injector coding as an example, as shown below. ▼

Hino		↑	📷	?
#1 INJ		Back		
#2 INJ		PgUp		
#3 INJ		PgDn		
#4 INJ		Print		
#5 INJ				
#6 INJ				

(18) Before entering a new nozzle coding, it needs to check whether the code is correct or not, the error code will not be allowed to write into the injector ECU, it will work after the confirmation and click **【OK】**. As shown below. ▼

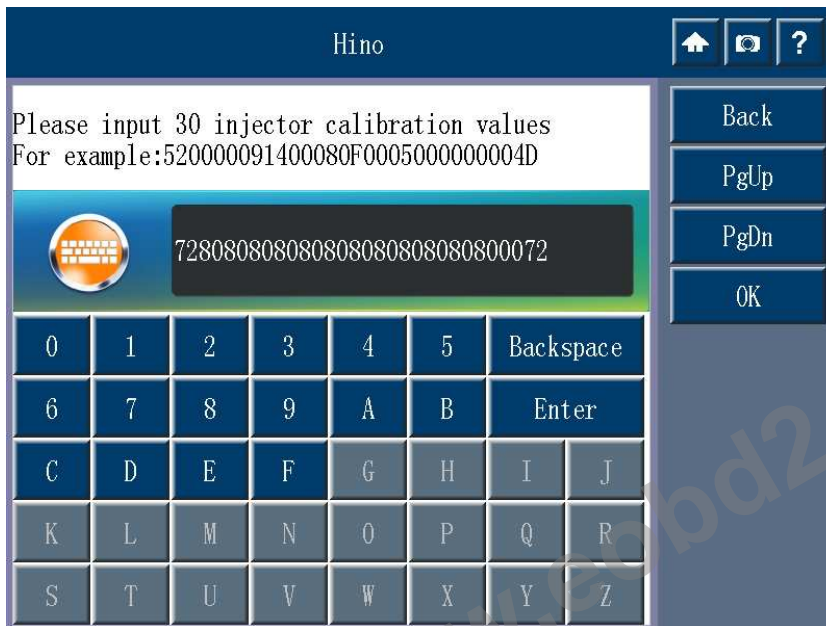

(19). If the communication is normal, screen will be displayed **【test end】** , which means the nozzle data into successfully, as shown below. ▼



Tip: Typically, only when replace the injector need the function “ Read and write of Nozzle code (QR code)” , maintenance staff in the preparation of the nozzle into the new coded nozzle should be further encoded to read, read out of the nozzle confirm whether the newly written code into the nozzle coding, write code to determine the correct nozzle.

### 3. Read vehicle information

(1) In the test function menu, select "vehicle data" menu to read the basic information of vehicles and vehicle data, as shown below. ▼

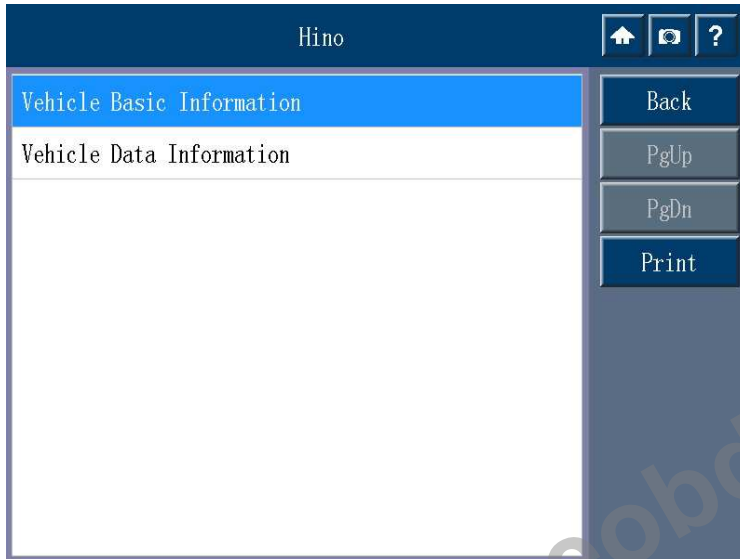

(2) Read basic information about the vehicle, as shown below. ▼

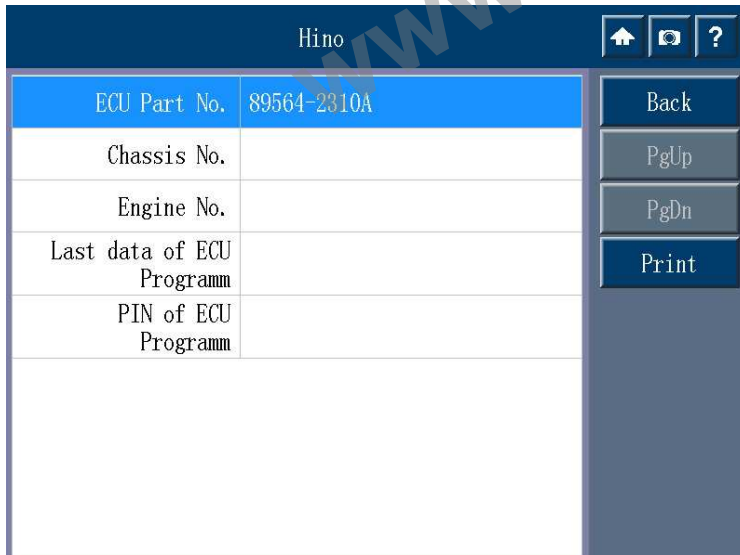

(3) Read vehicle data, as shown below. ▼



### Chapter III Block Diagnostic position of different models

Diagnosis truck seat sub graph (● Diagnostic Block location):

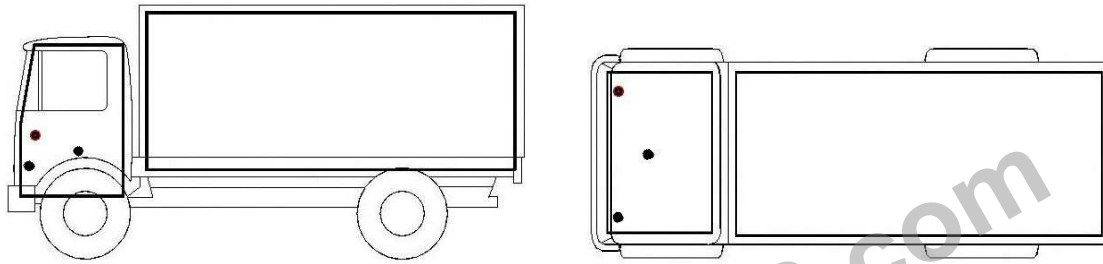

Block Diagnostic pickup location map:

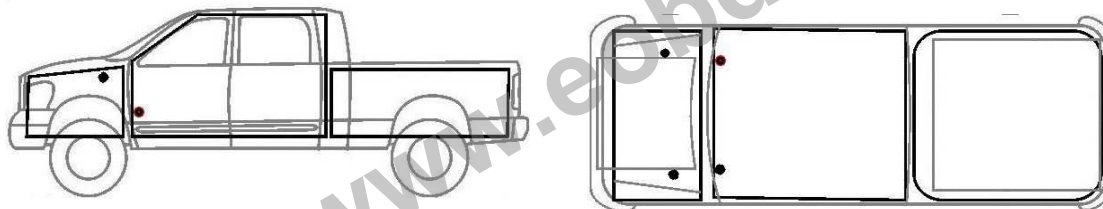

Diagnosis of medium-sized passenger seat location map:

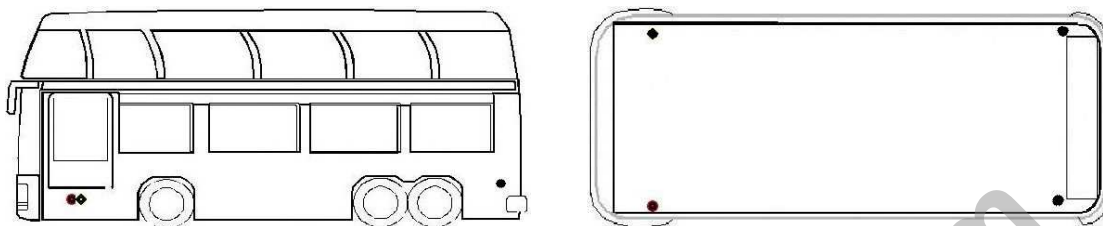

Block Diagnostic utility vehicle location map:

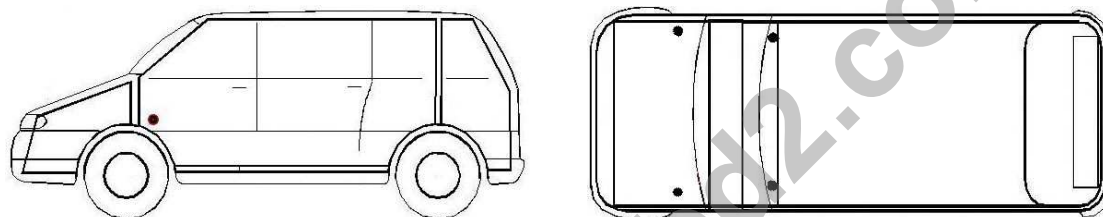

Location seat small car diagnostics:

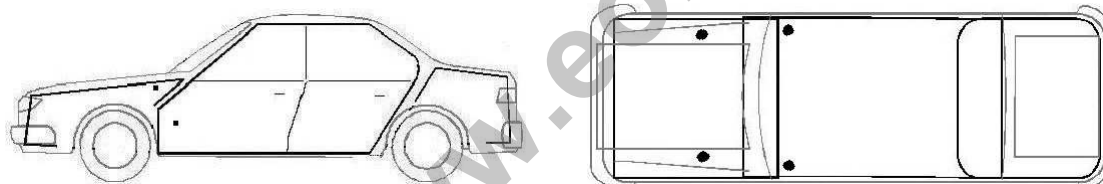

Tip:

Each vehicle manufacturer may select additional pin used to diagnose a variety of systems.

We can not guarantee that every manufacturer to comply in all respects the same standard. Therefore, this pin will be allocated with a different distribution as described. Pin assignments specified by the manufacturer according to the specific decision models and maintenance information.

## Chapter IV Definition of diagnostic seat and Communicational protocols

### A. common definition of diagnostic Block diagram and pin

(1) The standard OBD II Diagnostic Block Type:

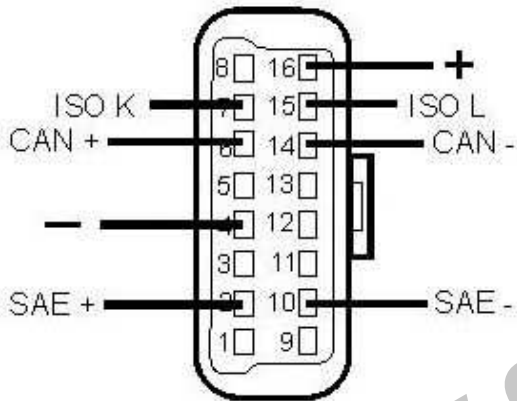

- Terminals:
- 2 # / 10 #: 2 and 10 for SAE diagnosis
  - 4 # / 5 #: Negative
  - 6 # / 14 #: 6 and 14 for CAN diagnosis
  - 7 # / 15 #: ISO, KWP K / ISO, KWP L diagnosis
  - 16 #: positive (12V/24V)

(2) Round 16PIN diagnostic Block (Denso, Bosch, Cummins):

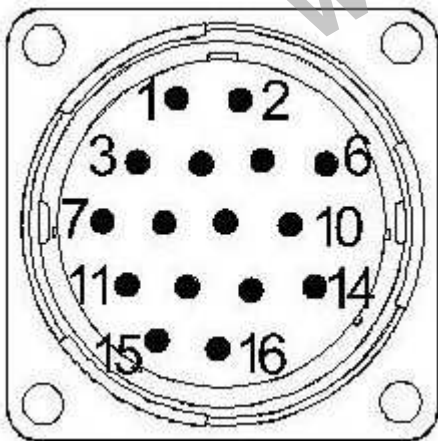

- Terminals:
- # 1: Positive
  - 2 #: Negative
  - 8 # / 7 # / 5 #: K Diagnosis
  - 11 #: CAN H diagnosis
  - 12 #: CAN L Diagnosis

(3) Round 37PIN diagnostic Block (MAN)

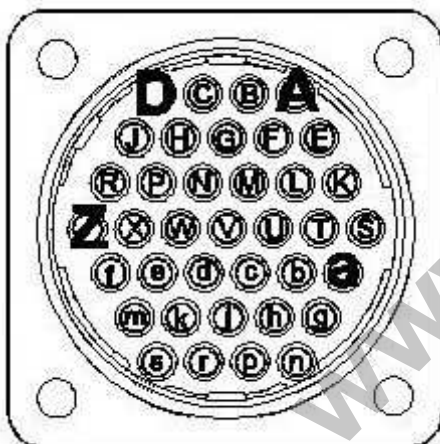

- Terminals:
- Other pins (not for diagnostic features)
  - A #: negative
  - D #: positive
  - a #: Engine Control System K line
  - Z #: Engine Control System L line
  - L #: auxiliary heater K line
  - P #: auxiliary heater L line
  - U #: Reducer K Line
  - V #: Reducer L Line

(4) round 38PIN diagnostic socket (Iveco models):

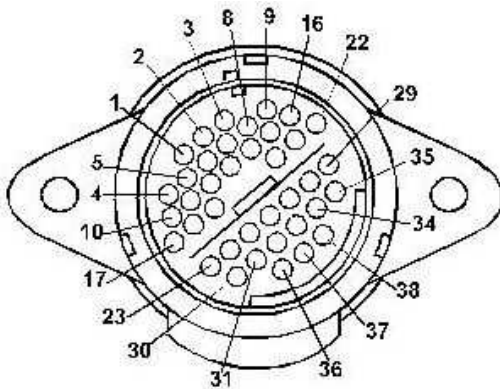

Terminals:

- 1 #: EDC / exhaust gas recirculation L line
- 2 #: EDC / exhaust gas recirculation K line
- 3 #: ABS; ABS / ABD L line
- 4 #: ABS; ABS / ABD K Line
- 5 #: SRS / Retarder L line
- 6 #: SRS / Retarder K Line
- 7 #: combination instrument L line
- 8 #: Combination meter / odometer K Line
- 9 #: secondary / supplementary heating L line
- 10 #: auxiliary / supplementary heater K Line
- 11 #: 15 terminals
- 12 #: start acceleration protection K line
- 13#: HVAC L line
- 14#: HVAC K Line
- 21 #: CAN BUS high
- 22 #: CAN BUS LOW
- 27 #: terminal 30 (positive)
- 28#: Speed
- 29 #: speed signal
- 30 #: ground (negative)

5) round 9PIN Diagnostic Block (Cummins, Bosch, Carter):

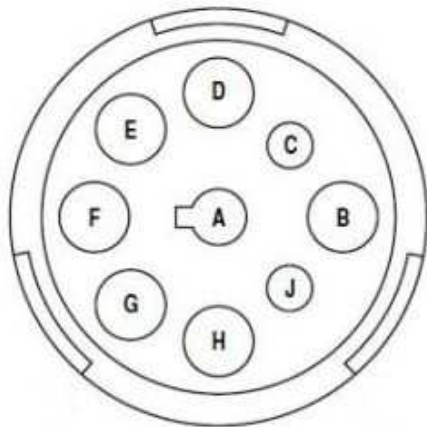

Terminals:

- A #: ground (negative)
- B #: power supply (positive)
- C #: CAN High 1
- D #: CAN Low 1
- E #: L line
- F #: RS-485+
- G#: RS--485-
- H #: CAN High 2
- J #: CAN Low 2



## 2. Using the multi-jumper box

### Tip:

If you use the OBD testing connectors for direct connection, can only detect the standard diagnostic connector pin out on the connected system (pin 7 for ISO diagnosis, pins 2 and 10 for SAE diagnosis, 6 and 14 pins for the CAN diagnosis). This is usually the engine control system, some cases may find other systems. All diagnostic criteria did not take out the plug pins on the OBD system must use the test connection with the 'million a jumper box' to the jumper connection test. In the use of 'million a jumper box' to the jumper connection test, click on that connection as follows:

### (1) the multi-jumper box

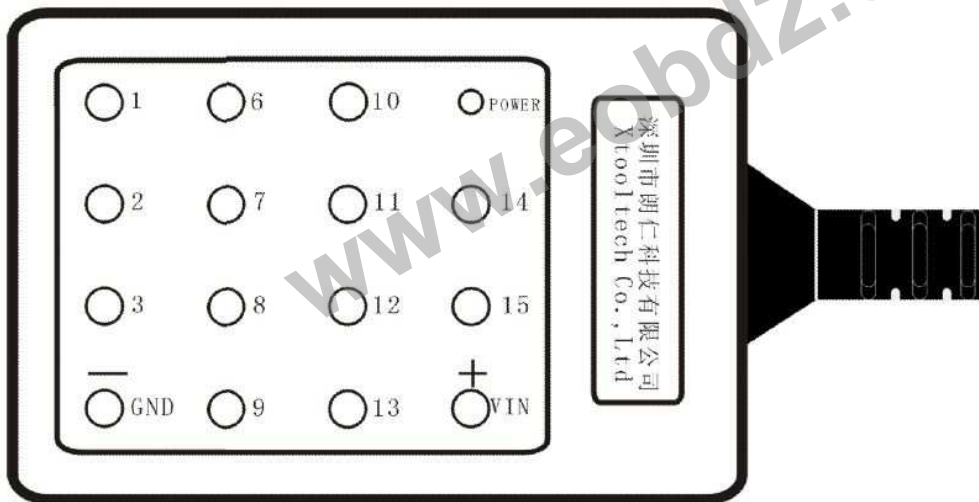

### (2) note of the side hole on multi-jumper box , it is visible on the label place of the box back.

Jumper box side hole	Definition	Jumper box side hole	Definition
1	CAN H2	9	232-TX
2	BUS+	10	BUS-
3	K-line2	11	CAN L2
4	GND negative	12	RS485-
5	GND negative	13	RS485+
6	CAN H1	14	CAN L1
7	K-line1	15	L-line
8	232-RX	16	VIN positive

### (3) using method of multi-jumper box

In the side with the hole in the **multi-jumper box** must be cross-wiring (in the configuration box) to connect. With a jumper in the use of **jumper box**, the need to first determine the type of the tested vehicle diagnostic blocks and protocol, according to the type of diagnostic blocks select the



corresponding cross-wiring to connect, jumper seat at one end and the vehicle diagnostic connector, the other end and the hole with a jumper to connect the terminal box.

Note that, before the connection is required in the diagnosis of vehicle seat multimeter voltage measurement terminals to determine the diagnosis of Block, the negative electrode and the socket. Confirm the connection before the test, the use of cross-wiring connected to the corresponding box with a jumper-side air.

Typically, the power for the 12V or 24V; K communication line is 12V or 24V; CAN H and CAN L to about 2.5V (the voltage sum of the two lines should be around 5V).

www.eobd2.com

www.eobd2.com